

# PLC SERIES

Screw connect and pull break couplings interchangeable with the DIN V Series probes

## INTRODUCTION

Holmbury's PLC Series screw connect couplings allow for connection under pressure and are ideal choice for agricultural applications with high pressure pulses.

## CONSTRUCTION

- Carbon steel with trivalent plating
- Fitted with Nitrile seals

## FEATURES

- Screw connection only possible with both halves of PLC Series
- Interchangeable with ISO A Series male (Size 12 ISO A only)
- Screw connect design eliminates brinelling
- Can be connected with residual pressure in the system
- Bidirectional flow

## ACCESSORIES

- Dust Caps and Plugs are available for the PLC Series



## SPECIFICATIONS

- Operating temperatures (with Nitrile seals): -40°C (-40°F) to 106°C (223°F)

## APPLICATIONS

- Agricultural applications
- General industrial

## ORDER CODES

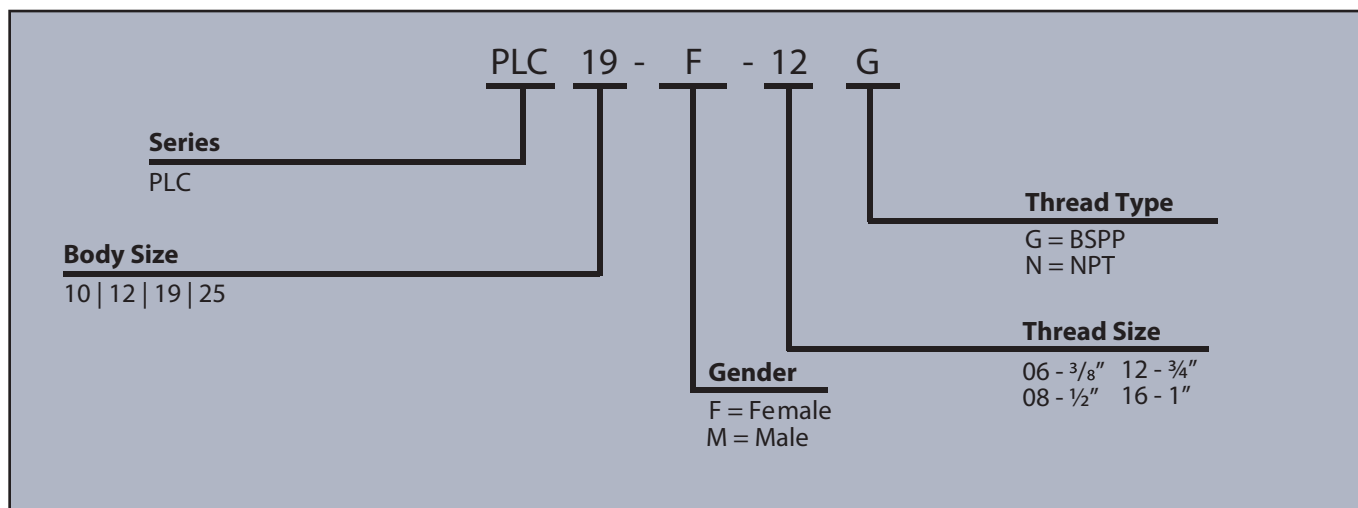

## DRAWING

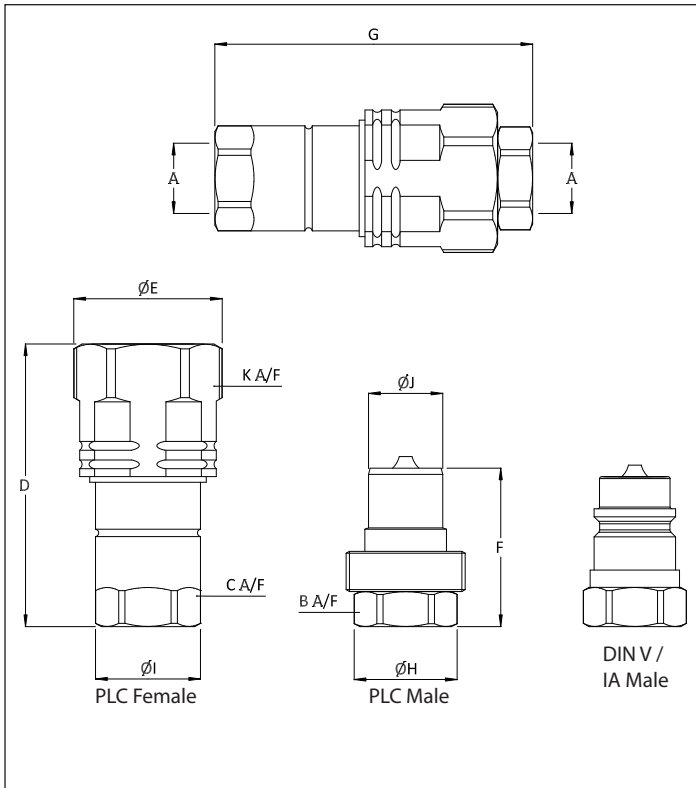

## PRESSURE DROP CHARACTERISTICS

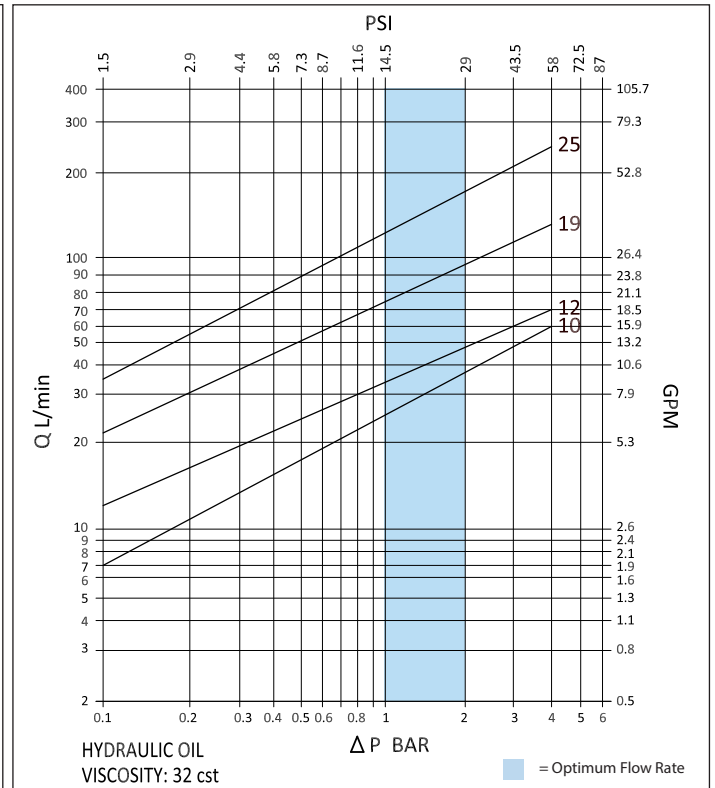

## DIMENSIONS

Size	Thread Size (A)	B	C	K	D	ØE	F	G	ØH	ØI	ØJ	Maximum Working Pressure	Burst Pressure (Coupled)	Burst Pressure (Male)	Burst Pressure (Female)
		Dimensions in mm										Bar			
		Dimensions in Inches										Psi			
PLC 10	3/8"	24.0	24.0	34.0	72.0	38.0	40.5	83.0	27.0	27.0	19.0	300	1600	1600	1550
		0.9	0.9	1.3	2.8	1.5	1.6	3.3	1.1	1.1	0.7	4350	23200	23200	22475
PLC 12	1/2"	27.0	27.0	38.2	82.0	42.0	49.0	95.8	30.0	30.0	20.5	300	1600	1550	1500
		1.1	1.1	1.5	3.2	1.7	1.9	3.8	1.2	1.2	0.8	4350	23200	22475	21750
PLC 19	3/4"	34.0	34.0	50.0	108.0	55.0	62.0	126.0	38.0	38.0	28.0	280	1300	1300	1300
		1.3	1.3	2.0	4.3	2.2	2.4	5.0	1.5	1.5	1.1	4060	18850	18850	18850
PLC 25	1"	41.0	41.0	55.0	124.0	61.0	73.0	144.5	45.5	44.0	31.5	250	1200	1200	1100
		1.6	1.6	2.2	4.9	2.4	2.9	5.7	1.8	1.7	1.2	3625	17400	17400	15950

PSI= Bar x14.5 Inches= mm/25.4

